

# FLOW

09.05.2025  
317657 317658

## Monteringsanvisning

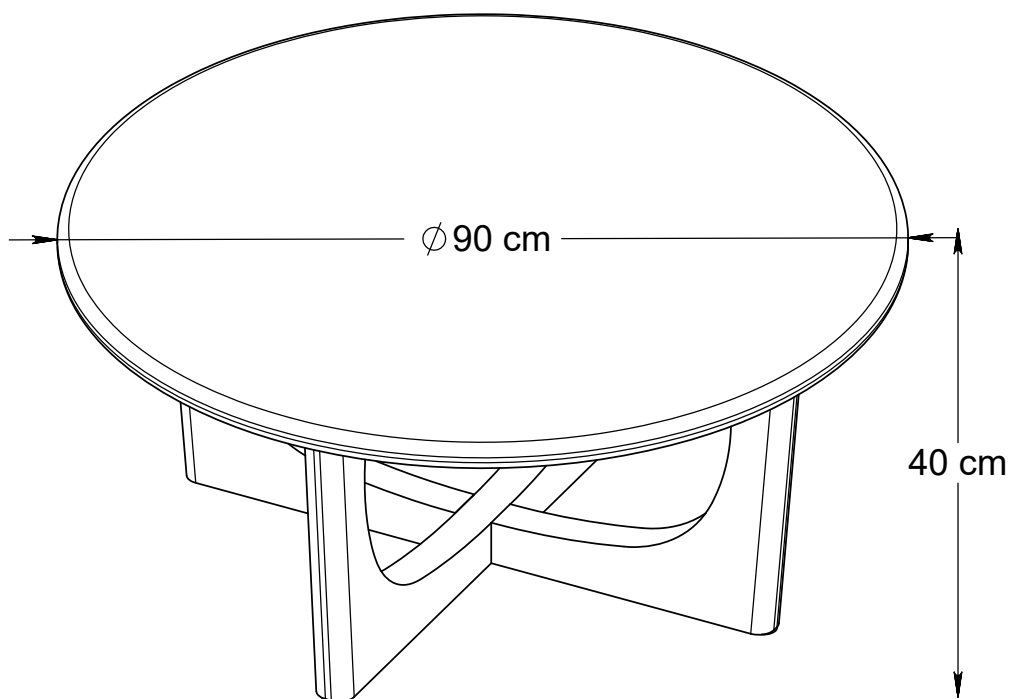

### VIKTIG !

DET MÅ IKKE BRUKES ELEKTRISK SKRUTREKKER  
VED MONTERING. HULLENE TIL SKRUENE ER I  
SPON ELLER PLAST, OG KAN ØDELEGGES VED  
BRUKT AV STOR KRAFT.

# Bohus

# 55551002

TEILCHECKLISTE  
LISTE DE CONTROLE  
LISTADO DE CONTROL  
TJEKLISTE  
CHECK LIST



Ref./No.	Ref./Art.	Qty./Stck./Quantité	Size / Maß / Dimension (mm)	Packed in box	✓
1	333464471	1	Ø900x30	1	
2	333465471	1	760x365x43	1	
3	333466471	2	358.5x365x43	1	

# 55551004

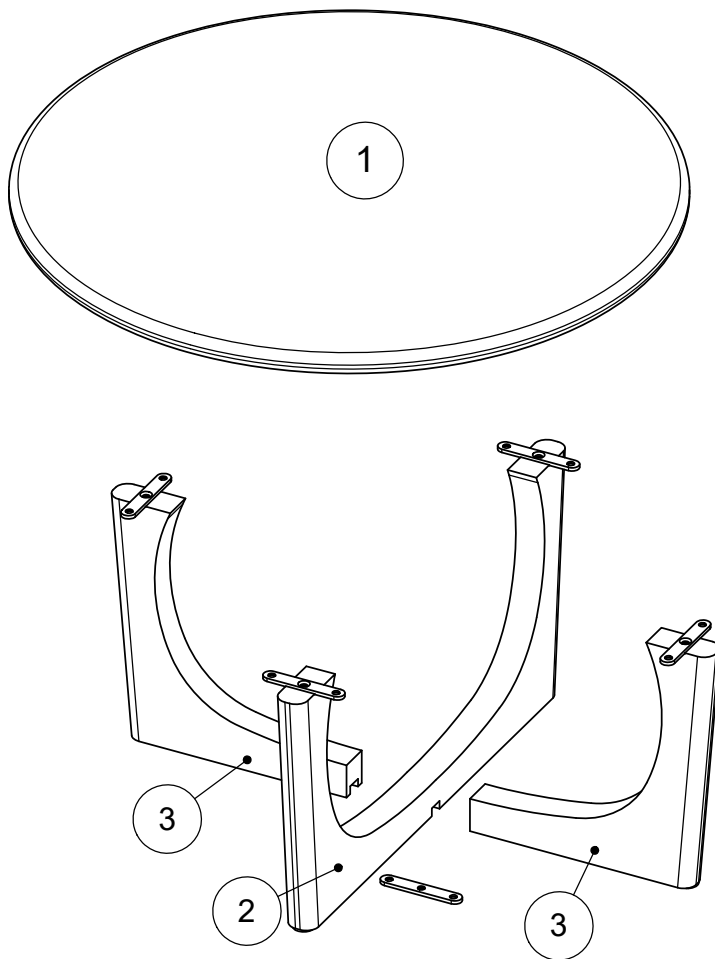
Ref./No.	Ref./Art.	Qty./Stck./Quantité	Size / Maß / Dimension (mm)	Packed in box	✓
1	333464256	1	Ø900x30	1	
2	333465256	1	760x365x43	1	
3	333466256	2	358.5x365x43	1	

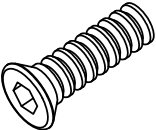
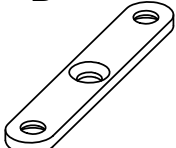
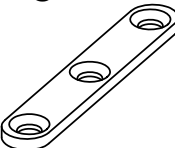

Réf./No.	Réf./Art.	Qty./Stck./Quantité	✓
A	233467	15	
B	233467	4	
C	233467	1	
D	233467	1	
E	233467	4	

15 - A	4 - B	1 - C	1 - D	4 - E	
 M8x20 mm	 120x20x5 mm	 120x20x5 mm	 5 mm	 Ø35x3 mm	

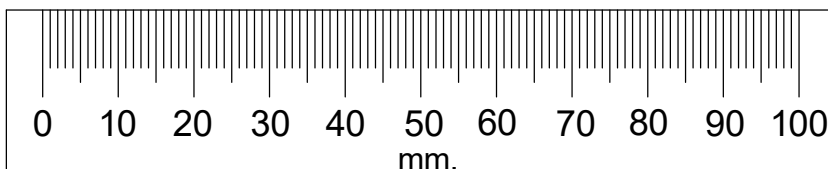
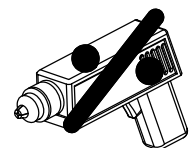
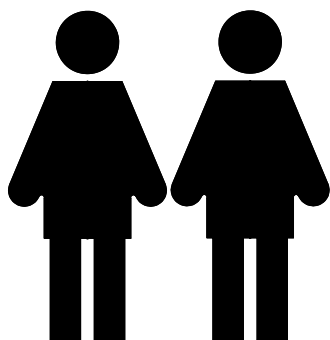

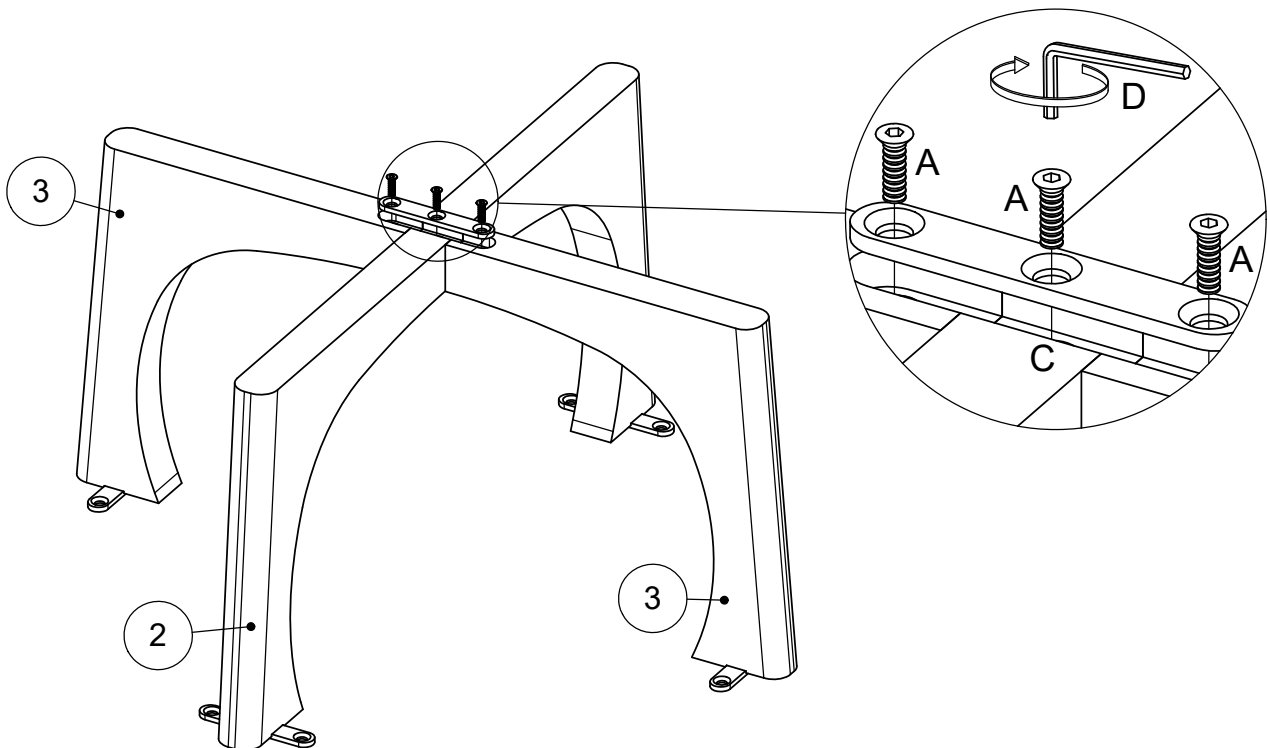
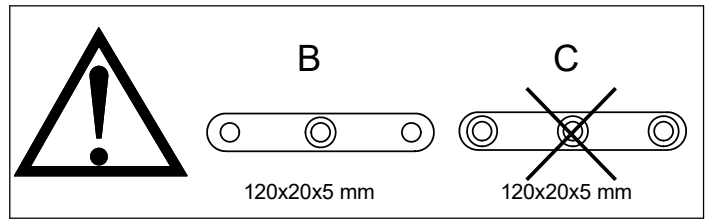
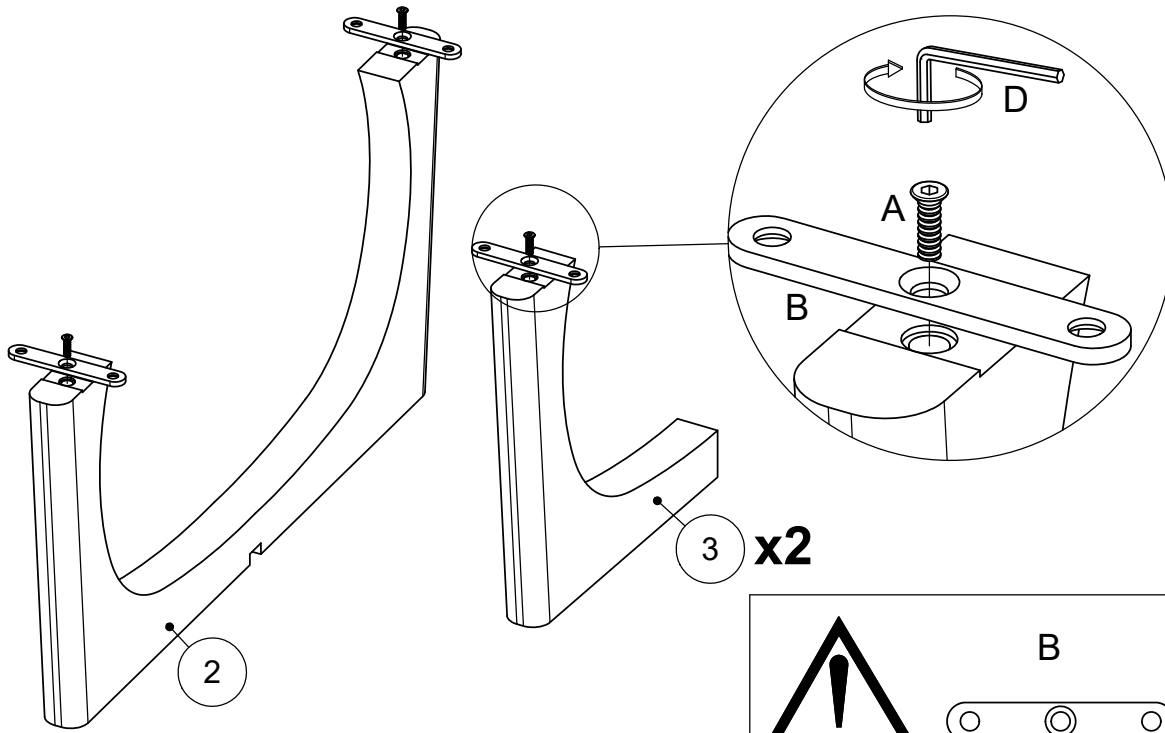

**3** A x 8  D x 1 

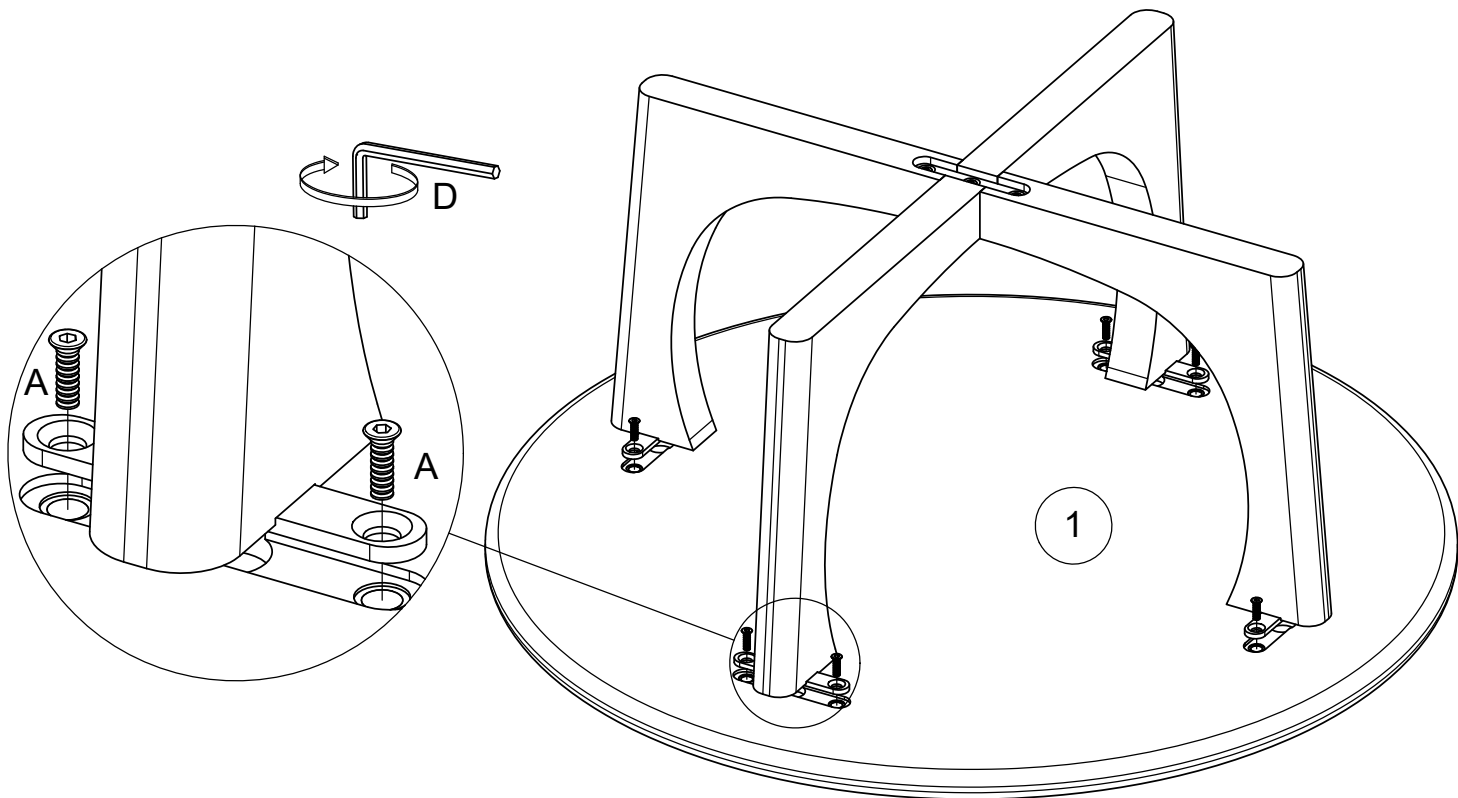

**4** E x 4 

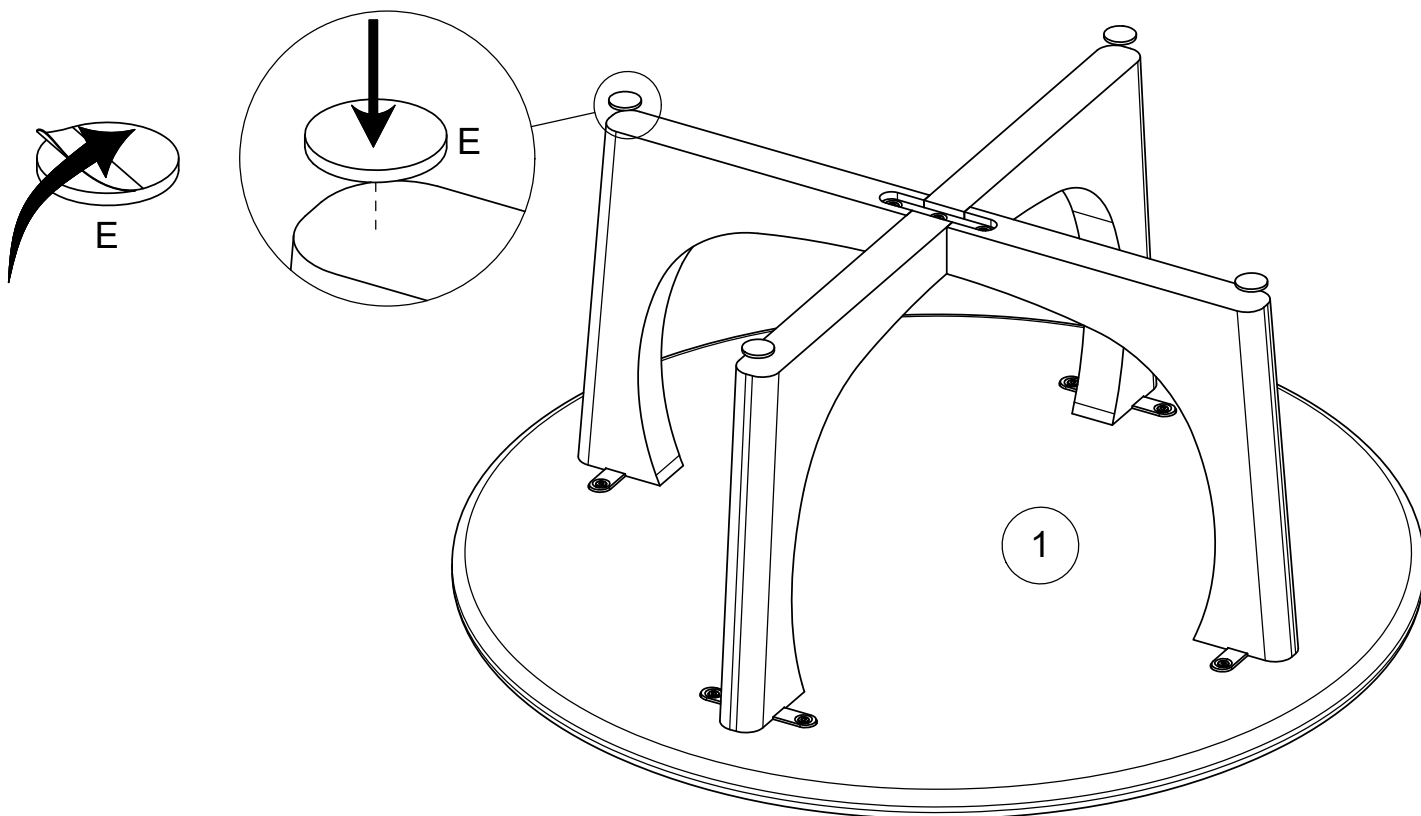

5

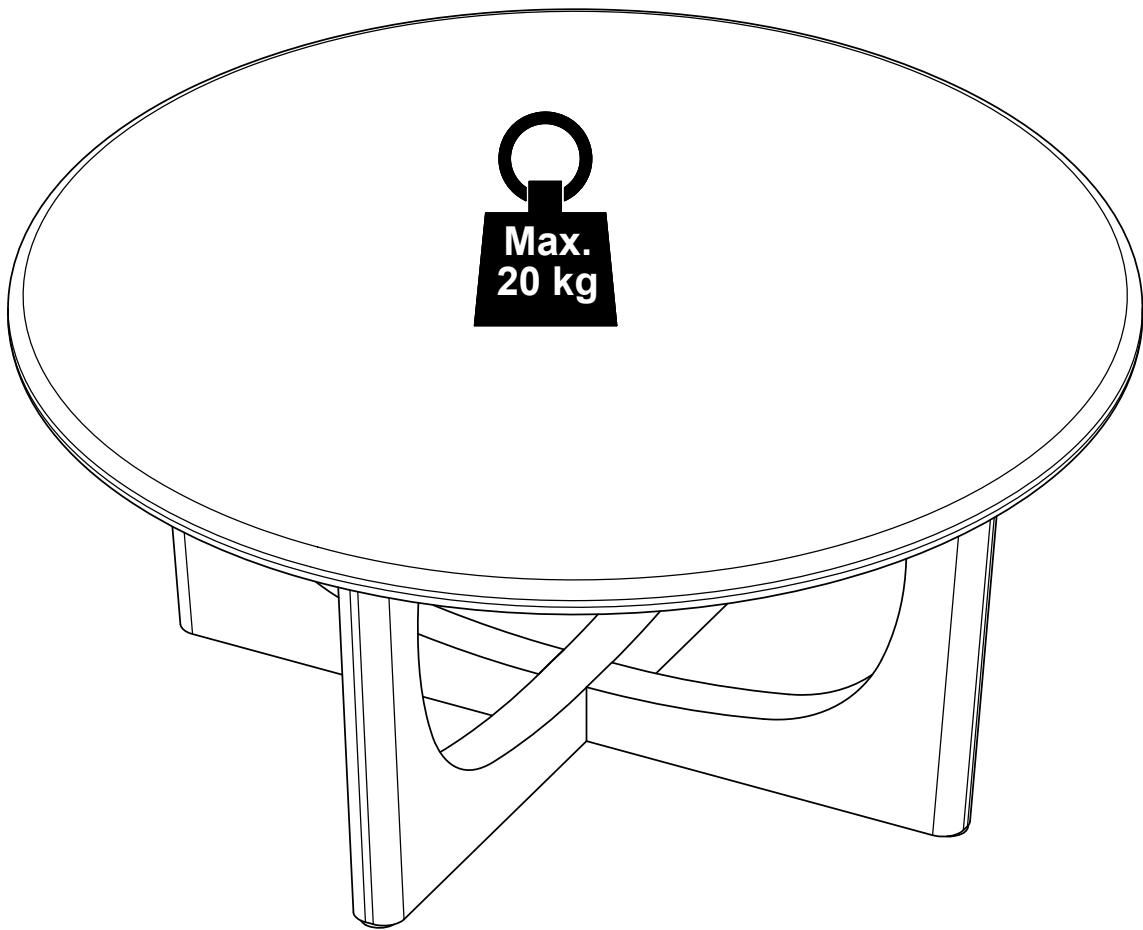



UK:

It is important that any product which is assembled using any kind of screw is re-tightened 2 weeks after assembly, and once every 3 months - in order to assure stability through-out the lifespan of the product.

DE:

Es ist wichtig, bei jedem mit Schrauben montierten Produkt diese 2 Wochen nach dem Zusammenbau sowie einmal alle 3 Monate wieder anzuziehen, um die Stabilität des Produkts über die gesamte Lebensdauer hinweg zu gewährleisten.

ES:

En el caso de los productos ensamblados, es importante volver a apretar los tornillos 2 semanas después del montaje y después cada 3 meses, para así preservar la estabilidad durante toda la vida útil del producto.

FR:

Il est important que tout produit monté à l'aide de vis soit resserré 2 semaines après son montage, puis tous les 3 mois, afin de garantir sa stabilité durant tout son cycle de vie.

DK: VIGTIGT!

Det er vigtigt, at alle produkter, der samles med alle former for skruer, efterspændes to uger efter samling samt hver tredje måned for at sikre, at produktet er stabilt i hele dets levetid.



UK:

Always ensure the feet / felt pads provided with this product are suitable for your flooring.  
Periodically check the position of any foot caps/felt pads used to ensure your floors are protected.

DE:

Wichtig : Bitte stellen Sie immer sicher , dass die mit diesem Produkt gelieferten FüÙe für Ihren Bodenbelag geeignet sind !  
Bitte überprüfen Sie regelmäßig die Position der verwendeten Fußkappen oder Filzgleiter um sicherzustellen dass Ihre Böden geschützt sind !

ES:

Asegúrese siempre que los tapones de las patas de este producto son compatibles con su suelo.  
Periódicamente revise que sus tapones y sus almohadillas de fieltro están correctamente colocadas para asegurar que su suelo esté protegido.

FR:

Assurez-vous toujours que les pieds/ patins fournis avec le produit sont compatibles avec le sol.  
Contrôlez régulièrement la position des patins utilisés pour que vos sols soient protégés.

DK:

Sørg altid for at beskyttelse fødder / filt-puderne der følger med dette produkt, passer til Deres gulv.  
Kontroller regelmæssigt placeringen at evt. beskyttelse fødder / filt-puder er korrekt placeret for bedste beskyttelse af gulvene.